

Looking ahead,
going beyond expectations
Ahead > Beyond



Submersible electric Pumps

Product Catalogue





Sectors and Areas of Application

- **Emptying of wells, garages and cellars**
For the emptying of domestic premises subject to flooding or water infiltrations.
- **Emptying of tanks and cisterns**
For aspiration from water recovery systems
- **Handling of load liquids of solid or filamentous substances in suspension**
For the drainage of sludge with solid or filamentous particles
- **Civil and industrial waste water evacuation**
For the drainage of discharges of residential or industrial uses
- **Drainage of sublevel areas**
For the extraction of water from lower level areas
- **Emptying of cesspools**
For the emptying residential and industrial sewage systems
- **The lifting of rainwater**
For movement of the water contained in rainwater recovery tanks
- **Irrigation of gardens and vegetable gardens**
For gardening and small-scale agriculture



Technology, performance, quality in two different forms: steel and cast iron

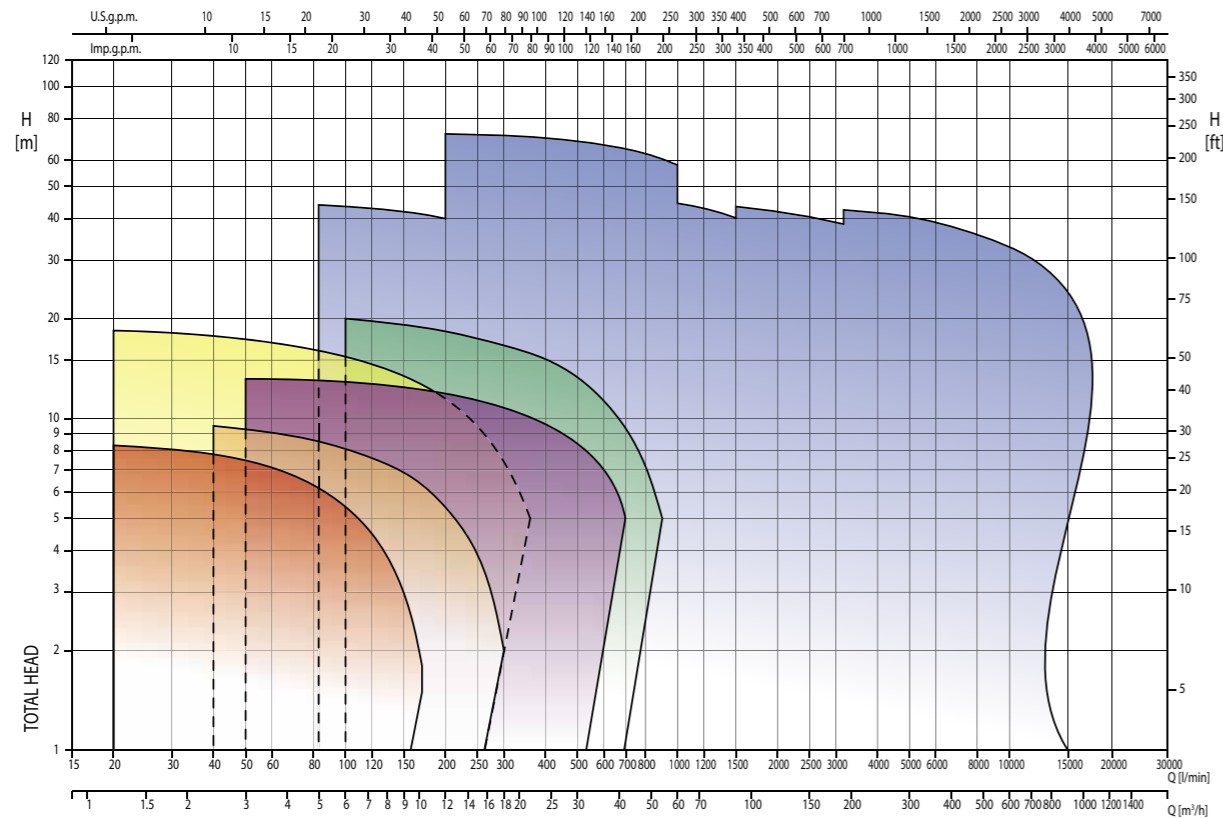

Technology, Performance, Quality: words that can take on different shapes and meanings. For EBARA they assume a **precise meaning**. They represent the characteristics that distinguish their products and that are also found in the wide range of submersed electric pumps: high technology used in production, performance of a very wide range that covers the most types of use, quality in the details and precision of the technical solutions adopted.

The submersed electric pumps summarise all this in two different families: steel submersibles and cast-iron submersibles. The **steel** range was also conceived and designed to offer high quality standards in the field of domestic applications.

The range of **cast iron** electric pumps, on the other hand, is ideal for residential and industrial uses and ensures high performance even in the most extreme situations.

The same quality, the same technology, the same EBARA imprint in two different forms: Steel and Cast iron.

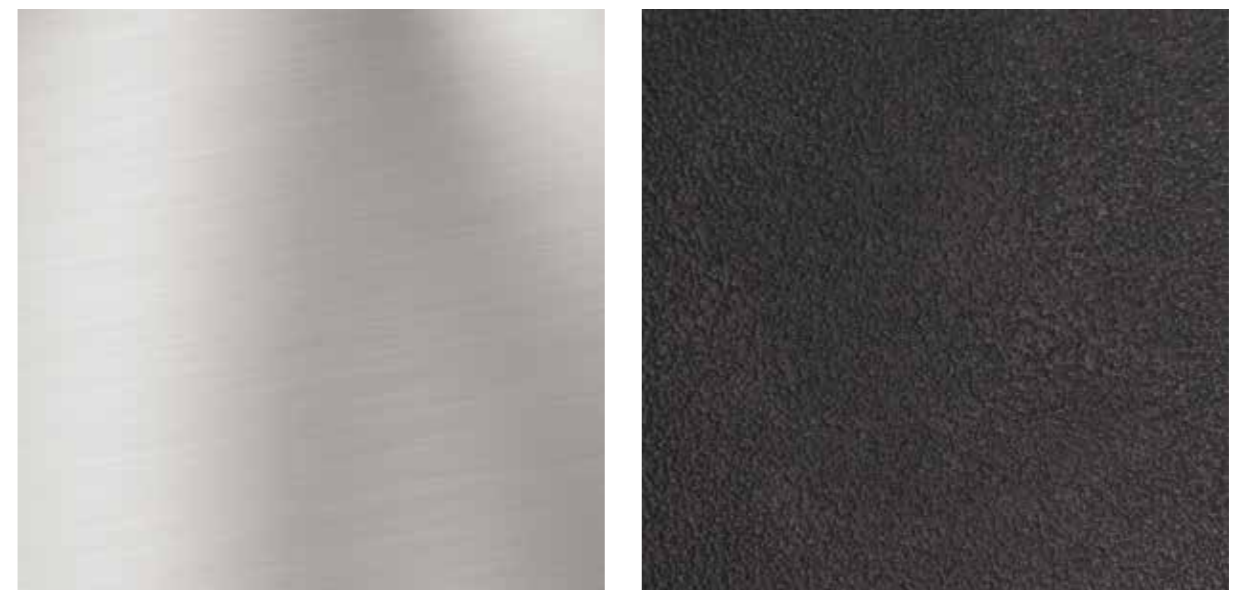

OPTIMA

Submersible pumps in AISI 304

Submersible electric pump for clear water with AISI 304 stainless steel hydraulics.

Pump body, intake grille, seal holder disc and motor casing are in AISI 304.

Impeller in PPE + PS reinforced with glass fibres and shaft in AISI 303.

The mechanical seal is standard (Ceramic/Carbon/NBR)

- MA version (fig.1) with float

- MS version (fig.3) with MS vertical magnetic float with reduced dimensions for clean water

Accessories

- 1"¼ hose connector and relative hose clamp (optional)
- Minimum suction device up to 3 mm (fig. 2)



Practical and easy to use



Possibility of use in fixed and mobile installations



Resistant to corrosion

- Total head from 1.5 to 7.6 m
- Capacity from 1.2 to 9 m³/h
- Maximum immersion 5 m
- Maximum liquid temperature 50°C
- Maximum solid size passage 10 mm



Performance curve

50Hz

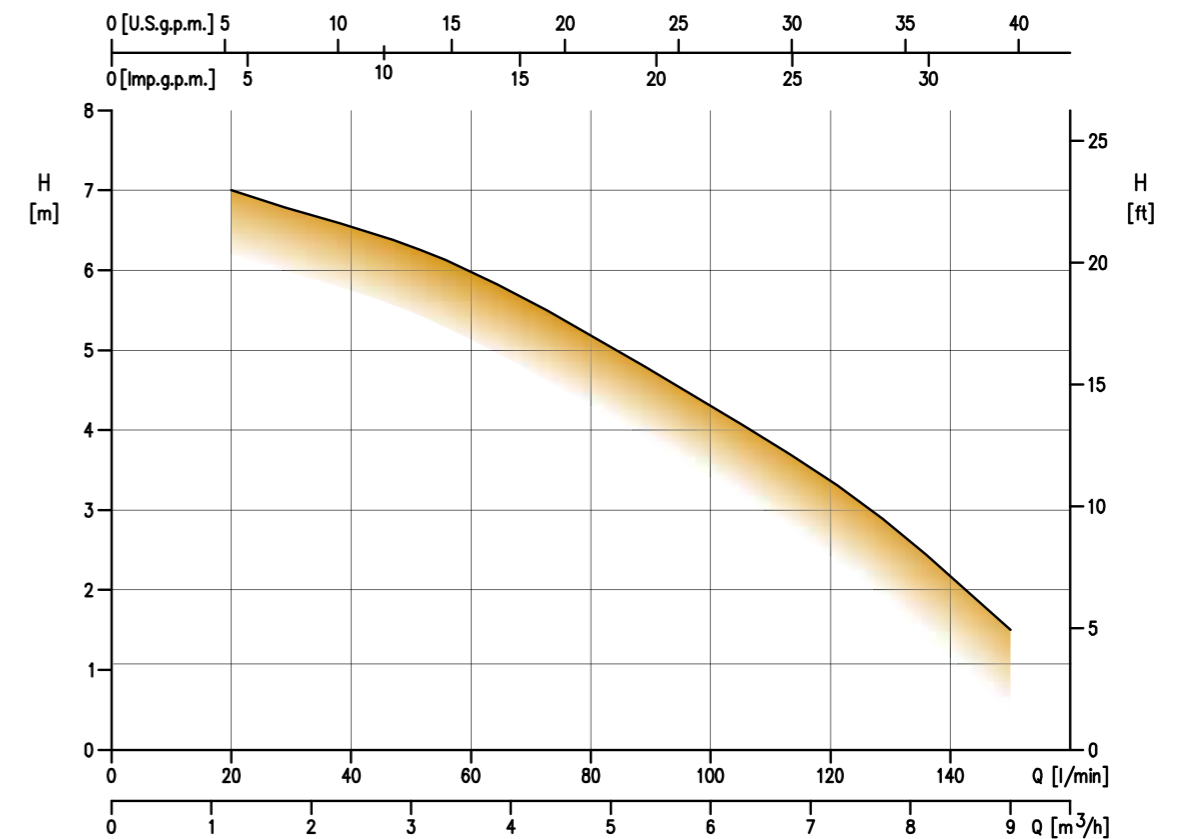

INSTALLATION

The OPTIMA electric pumps have a wide versatility of installation. The possibility of choosing between the vertical magnetic float (small) or the float switch allows choosing of the best option, also based on the space available to insert the pump. Furthermore, the choice of switch type also depends on the water level for which pump start is preferred.

OPTIMA MS

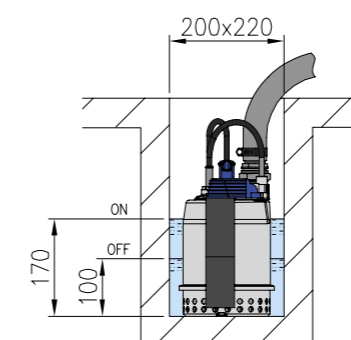

OPTIMA MA

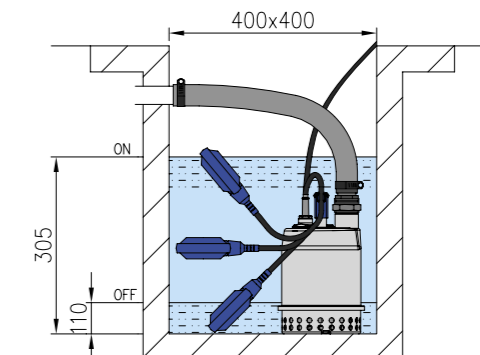

BEST ONE - ONE VOX

Fully submersed electric pumps in AISI 304



Possibility of use in fixed and mobile installations



Resistant to corrosion



Practical and easy to use

Submersible electric pump for clear water with AISI 304 stainless steel hydraulics. Outer casing, impeller, filter, motor cover, seal holder disc and motor case all in AISI 304, shaft in AISI 303. The mechanical seal is standard in Ceramic/Carbon/NBR. Provided with 5 m of power cable type H05 RN - F (single phase), H07 RN - F (three phase) for internal use, with or without float.

Special Versions

- Version MA (fig. 1) with float
- Version VORTEX (VOX) (fig. 2)
- Version MA (fig. 3) with magnetic float MS vertical with reduced dimensions for clean water

Accessories

- 1 1/4" hose connector and relative hose clamp (optional)
- Minimum suction device up to 3 mm (fig. 4)

- Total head from 1.8 to 8.3 m for BEST ONE and from 1.5 to 6 m for BEST ONE VOX
- Capacity from 1.2 to 10.2 m³/h
- Maximum immersion 5 m
- Maximum liquid temperature 50°C
- Maximum solid size passage:
 - 10 mm
 - 20 mm for version VOX (VORTEX)



Low suction device
It allows aspiration to 3 mm from the ground (only for M and MA version). Easily mountable with simple pressing.

MS magnetic float (vertical)
It allows the use of floating pumps where space is limited (not compatible with low suction device)

Performance curve

50Hz

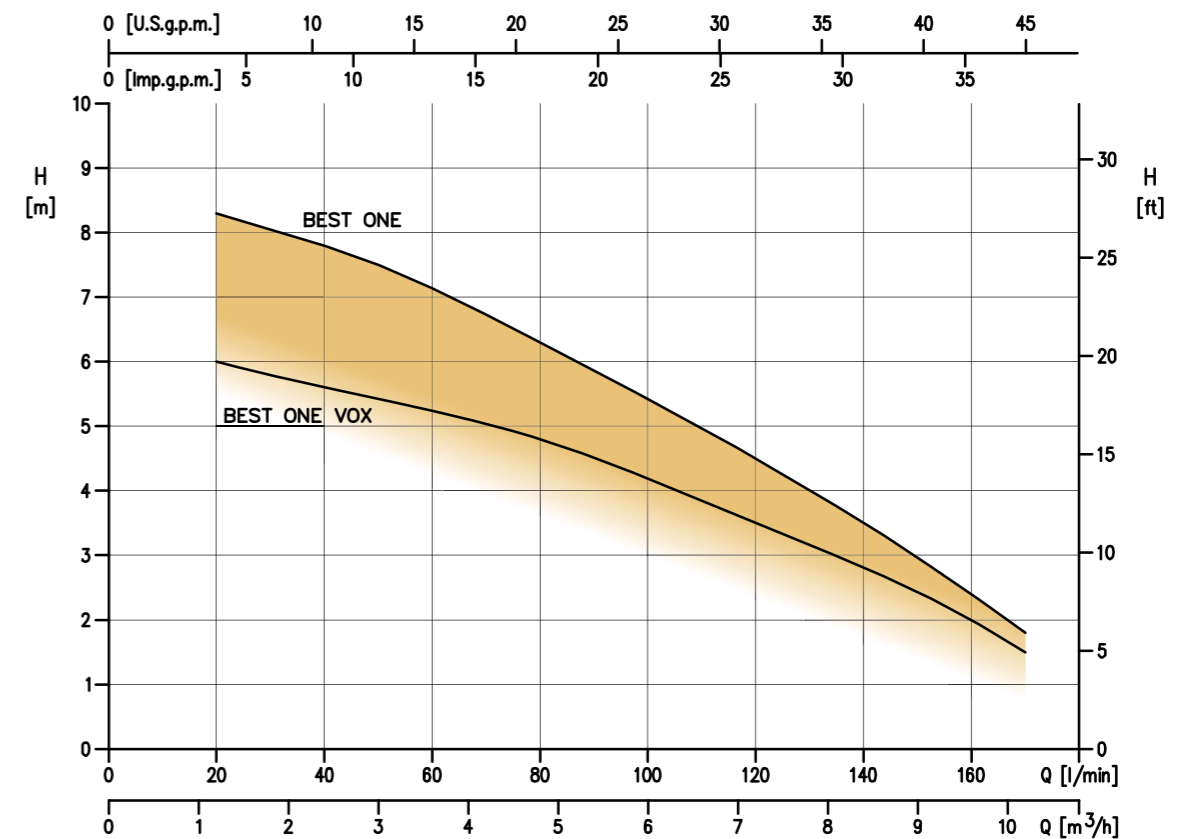

INSTALLATION

The BEST ONE electric pumps have a wide versatility of installation. The possibility of choosing between the vertical magnetic float (small) or the float switch allows choosing of the best option also based on the space available to insert the pump. Furthermore, the choice of switch type also depends on the water level for which pump start is preferred.

BEST ONE MS

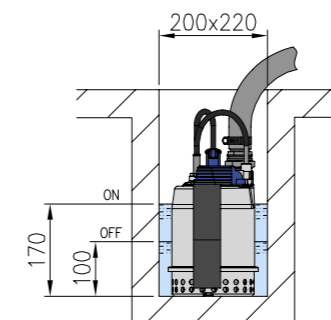

BEST ONE MA

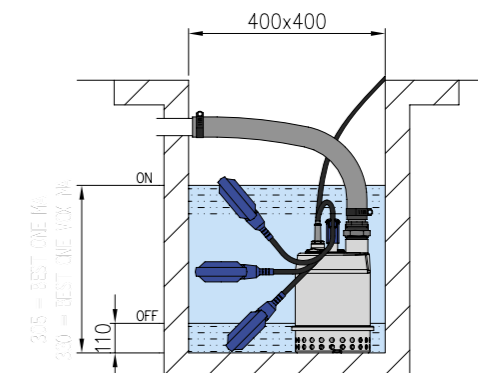

BEST 2-5

Submersible pumps in AISI 304

Submersible electric pump completely in AISI 304 stainless steel.

The pump body, the impeller, the suction grille, the motor cover, the seal holder disc and the motor case are in AISI 304.

The shaft is in AISI 303 (part in contact with the liquid). Double mechanical seal with oil chamber: the upper one in Carbon/Ceramic/NBR (motor side), the lower one in SiC/SiC/NBR (pump side).

Special Versions

- MA Version with float



Possibility of use in fixed and mobile installations



Practical and easy to use

- Total head from 2.9 to 18.4 m
- Capacity from 1.2 to 21.6 m³/h
- Maximum immersion 7 m
- Maximum liquid temperature 35°C
- Maximum solid size passage 10 mm



Performance curve

50Hz

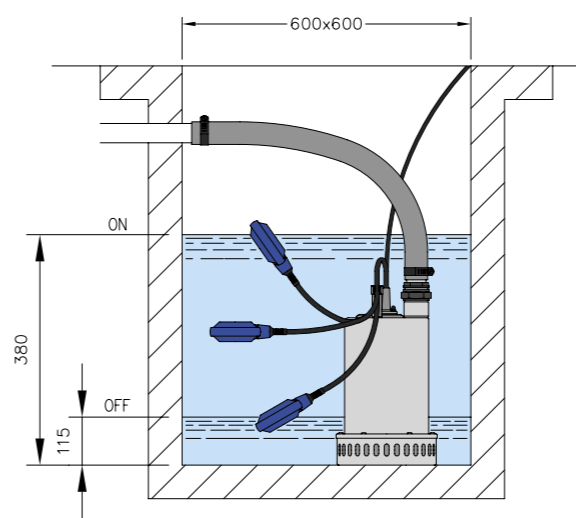
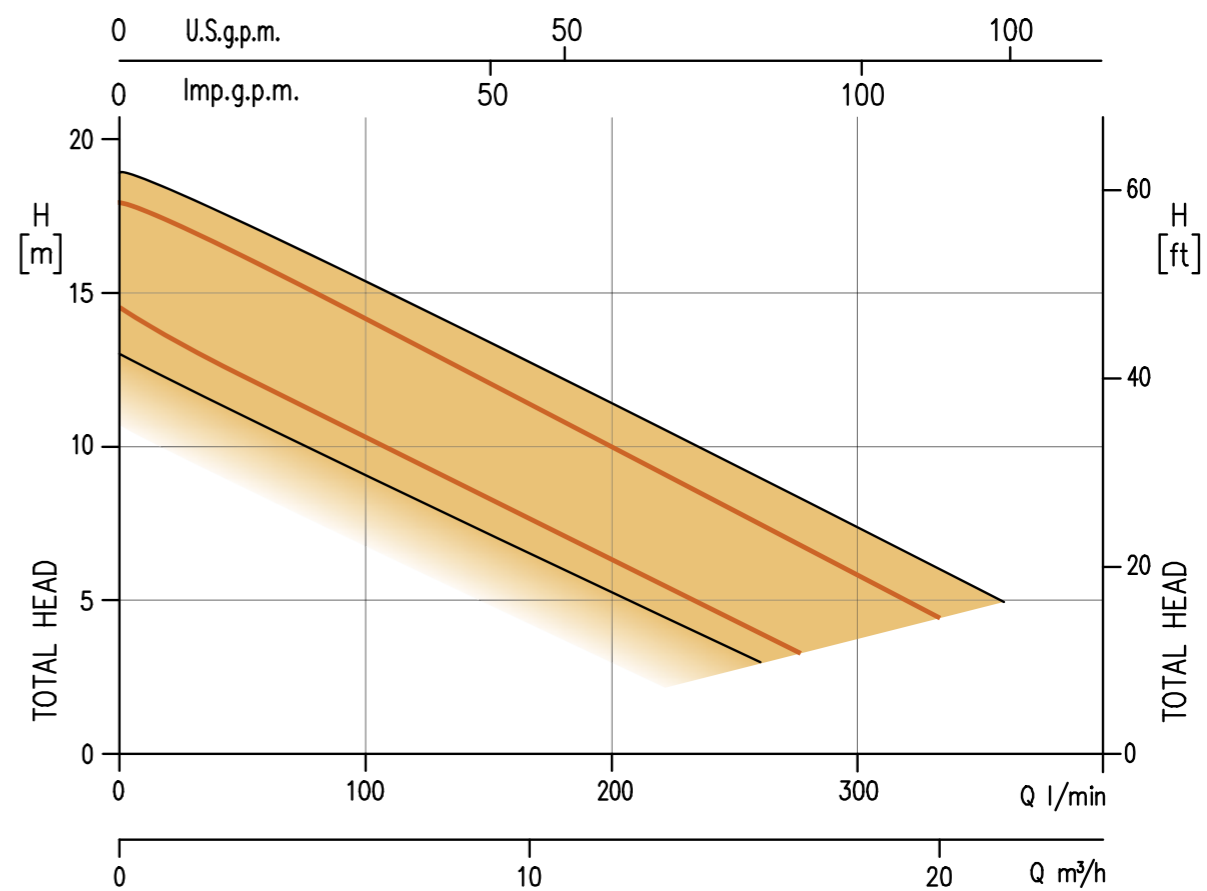

INSTALLATION

The BEST 2 - 5 electric pumps are also available with a float switch, thus increasing the versatility of use. The choice of the use of the float switch requires the respecting of minimum installation spaces to guarantee correct operation of the pump itself.



EBARA Pumps Europe S.p.A.

Via Torri di Confine 2/1 int. C
36053 Gambellara (Vicenza), Italy
Phone +39 0444 706811
Fax +39 0444 405811
ebara_pumps@ebaraeurope.com
www.ebaraeurope.com

EBARA Corporation

11-1, Haneda Asahi-cho, Ota-ku,
Tokyo 144-8510
Japan
Phone +81 3 6275 7598
Fax +81 3 5736 3193
www.ebara.com

